

DOME CAMERA

IK-DP20A

Please read this manual thoroughly before use, and keep it handy for future reference.

Record in space provided below the Model No. and the Seral No. as found on the label on the bottom of this unit.
Model. No. IK-DP20A Serial No. _____
Retain this information for future reference.

TABLE OF CONTENTS

Important Safeguards	
1. Features & Description	3
2. Cautions	3
3. Components	3
4. Part names and Locations.....	4
5. Connections	5
6. Operation	6
7. Menu Directory	24
8. Preset Commands	26
9. Installation	27
10. Switch Setting	30
11. Specifications	33

IMPORTANT SAFEGUARDS

1. Road Instructions

All the safety and operating instructions should be read before the product is operated.

2. Retain Instructions

The safety instructions and instruction manual should be retained for future reference.

3. Heed Warnings

All warnings on the product and in the instruction manual should be adhered to.

4. Follow Instructions

All operating and use instructions should be followed.

5. Cleaning

Disconnect this video product from the power supply before cleaning.

6. Attachments

Do not use attachments not recommended by the video product manufacturer as they may cause hazards.

7. Water and Moisture

Do not use this video product near water-for example, near a bath tub, wash bowl, kitchen sink, or laundry tub, in a wet basement, or near a swimming pool and the like.

8. Accessories

Do not place this video product on an unstable cart, stand, tripod, bracket or table. The video product may fall, causing serious injury to a child or adult, and serious damage to the product. Use only with stand, tripod, bracket, or table recommended by the manufacturer, or sold with the video product. Any mounting of the product should follow the manufacturer's instructions, and should use a mounting accessory recommended by the manufacturer.

9. Ventilation

This video product should never be placed near or over a radiator or heat register. This video product should not be placed in a built-in installation such as a bookcase or rack unless proper ventilation is provided or the manufacturer's instructions have been adhered to.

10. Power Sources

This video product should be operated only from the type of power source indicated on the marking label. If you are not sure of the type of power supply to your location, consult your product dealer.

11. Power-Cord Protection

Power-Supply cords should be routed so that they are not likely to be walked on or pinched by items placed upon or against them, paying particular attention to cords at plugs, screws and the point where they exit from the product.

12. Lightning

For added protection for this video product during a lightning storm, or when it is left unattended and unused for long periods of time, unplug it from the wall outlet and disconnect the power supply and cable system. This will prevent damage to the video product due to lightning and power-line surges.

13. Overloading

Do not overload power supply and extension cords as this can result in a risk of fire or electric shock.

14. Object and Liquid Entry

Never push objects of any kind into this video product through openings as they may touch dangerous voltage points or short-out parts that could result in a fire or electrical shock. Never spill liquid of kind on the video product.

15. Servicing

Do not attempt to service this video product yourself as opening or removing covers may expose you to dangerous voltage or other hazards. Refer all servicing to qualified service personnel.

16. Damage Requiring service

Disconnect this video product from the power supply and refer servicing to qualified service personnel under the following conditions.

- a. when the power-supply cord or plug is damaged.
- b. If liquid has been spilled, or objects have fallen into the video product.
- c. If the video product has been exposed to rain or water.
- d. If the video product does not operate normally by following the operating instructions in the instruction manual. Adjust only those controls that are covered by the instruction manual as an improper adjustment of other controls may result in damage and will often require extensive work by a qualified technician to restore the video product to its normal operation.
- e. If the video product has been dropped or the cabinet has been damaged.
- f. When the video product exhibits a distinct change in performance-this indicates a need for service.

17. Replacement Parts

When replacement parts are required, be sure the service technician has used replacement parts specified by the manufacturer of have the same characteristics as the original part. Unauthorized substitutions may result in fire, electric shock or other hazards.

18. Safety Check

Upon completion of any service or repairs to this video product, ask the service technician to perform safety checks to determine that the video product is in proper operating condition.

	CAUTION RISK OF ELECTRIC SHOCK DO NOT OPEN	
---	---	---

- The CAUTION label, shown on the left, is attached on the camera.

CAUTION TO REDUCE THE RISK OF ELECTRIC SHOCK,
DO NOT REMOVE COVER.
NO USER SERVICEABLE PARTS INSIDE.
REFER SERVICING TO QUALIFIED SERVICE PERSONNEL.



The lightening flash with arrowhead symbol, within an equilateral triangle, is intended to alert the user to the presence of uninsulated "dangerous voltage" within the product's enclosure that may be of sufficient magnitude to constitute a risk of electric shock to persons.

WARNING :
TO REDUCE THE RISK OF FIRE OR ELECTRIC SHOCK, DO NOT EXPOSE THIS APPLIANCE TO RAIN OR MOISTURE.



The exclamation point within an equilateral triangle is intended to alert the user to the presence of important operating and maintenance (servicing) instructions in the literature accompanying the appliance.

• **CAUTION**
CONNECT 24V AC UL LISTED CLASS 2 POWER SUPPLY.

FIELD INSTALLATION MARKING :
WORDED : "THIS INSTALLATION SHOULD BE MADE BY A QUALIFIED SERVICE PERSON AND SHOULD CONFORM TO ALL LOCAL CODES."

INFORMATION

This equipment has been tested and found to comply with the limits for a Class A digital device, pursuant to Part 15 of the FCC Rules. These limits are designed to provide reasonable protection against harmful interference when the equipment is operated in a commercial environment. This equipment generates, uses, and can radiate radio frequency energy and, if not installed and used in accordance with the instruction manual, may cause harmful interference to radio communications. Operation of this equipment in a residential area is likely to cause harmful interference in which case the user will be required to correct the interference at his own expense.

USER-INSTALLER CAUTION : Your authority to operate this FCC verified equipment could be voided if you make changes or modifications not expressly approved by the party

1. Features and description :

IK-DP20A has following function.

Quick Install Design - Cuts Installation Time in Half

480 Lines Horizontal Resolution

300 Degree/Second Pan

18X Optical/12X Digital Zoom

Privacy Zone Masking function

0.01 Lux Minimum Illumination (1/4, IR Cut filter Off)

50dB Signal-To-Noise Ratio

64 Position Preset

Auto-Flip

Proportional Zoom

2. Cautions :

- (1) In order to protect the camera, avoid placing or using it under direct sunlight, rain or dust.
- (2) Avoid touching the zoom lens with your fingers. If necessary, use a soft cloth moistened with alcohol to wipe off any dust.
- (3) When the camera is not in use, keep the lens cap attached to protect the zoom lens.
- (4) Avoid aiming the camera at the sun.
- (5) Avoid shooting the smear at intense light. Intense light such as a spotlight may cause a bloom or smear. A vertical stripe may appear on the screen. However, this is not a malfunction.
- (6) Install the camera away from video noise. If cables are wired near electric lighting wires or a TV set, noise may appear in images. In this event, relocate cables or reinstall equipment.

3. Components :

- | | |
|----------------------------|---|
| (1) Dome base | 1 |
| (2) Dome drive | 1 |
| (3) Accessories | |
| Instruction manual | 1 |
| Install screw (3PCS) | 1 |

4. Part names and Locations :

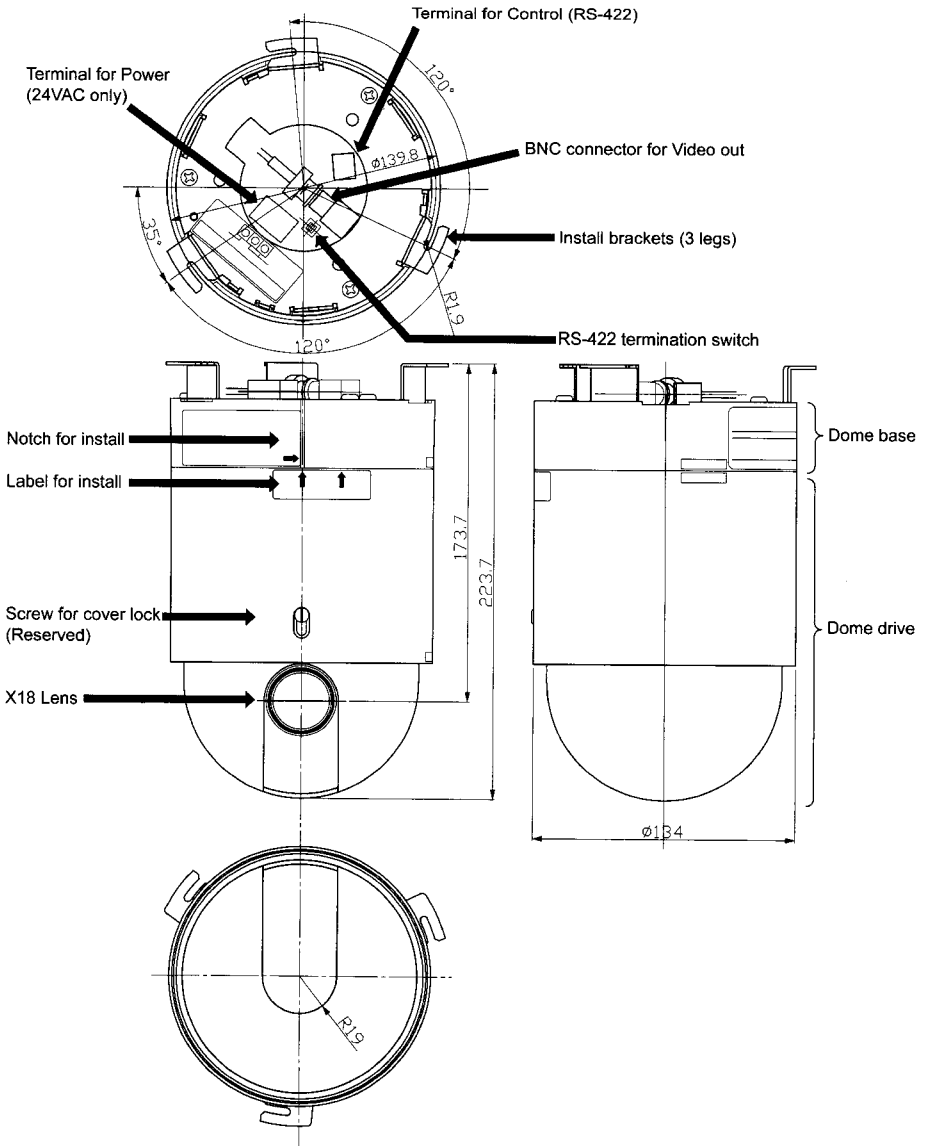

5. Connections :

Basic connection (Direct mode)

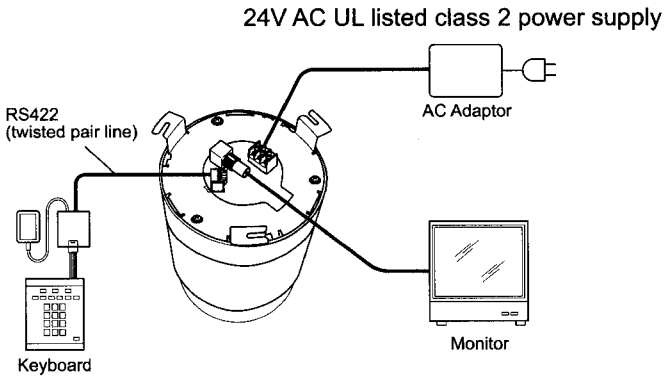

Make sure to connect to a power supply that allows for at least 35W consumption.

RS422 Pin Out

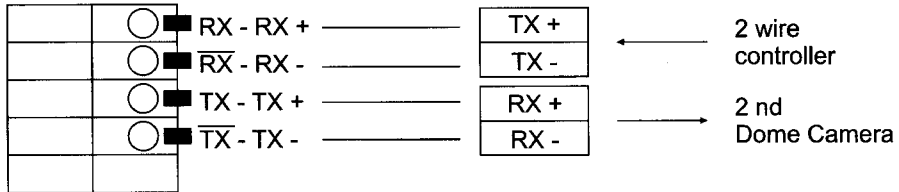

In the direct mode. Tx of the communication line from the keyboard is connected to Rx of the dome, and Tx - is connected to Rx - of the dome.

When connecting between two or more dome cameras by the daisy chain, Tx of the first dome and Rx of the following dome are connected and Tx - of the first dome and Rx - of the following dome are connected.

Note: KBD200/300/300V, CM6700, and MPT9500 are the products of Pelco.

6. Operation :

(Power On display)

TOSHIBA IK-DP20A
VERSION ***
PROTOCOL TOSHIBA-P
ADDRESS 1
COMM 4800/N/8/1

When the dome camera powers-up, the software version, selected protocol, and other information are displayed on the monitor.

6.1 ACCESSING THE MENU

Accessing the menu varies with the model controller being used. Several controllers are listed below. Please refer to your model's instructions for information on inputting commands.

JK-UC1

Input 95 using the numeric keypad.

Press the PRESET button to display the MENU screen.

KBD200/300/300V direct

Input 95 using the numeric keypad.

Hold down the PRESET button until the MENU screen is displayed.

KBD200/300/300V CM6700 mode

Input 95 using the numeric keypad.

Hold down the PRESET button until the Edit LABEL screen of CM6700 is displayed.

Press the TILT UP/DOWN button until SET is chosen.

Press the ACK button to display the MENU screen.

MPT9500

Input 95 using the numeric keypad.

Press the PRESET SET button.

Press the F2 button to display the MENU screen.

6.2 PAN/TILT FUNCTIONS

Manual PAN

Manual Pan is controlled from a keyboard and the speed ranges from 0.1 degrees/sec to 90 degrees/sec depending on the joystick position. In turbo mode the speed is 150 degree/sec. However, this speed is limited when Proportional P/T is ON.

Manual TILT

Manual Tilt speed ranges from 0.1 degrees/sec 45 degrees/sec. However, this speed changes when Proportional P/T is ON.

Pan Range	360degrees continuous
Tilt Range	85 degrees(Indoor), 92 degrees(Outdoor)
Manual Pan*Speeds	0.1°~90°/s
Manual Pan Speeds (turbo)	150°/s
Manual Tilt Speeds	0.1°~45°/s
Preset Speeds	Pan:300°/s max-set in menu Tilt:200°/s

6.3 SCAN FUNCTIONS

AUTO SCAN

The dome camera can perform an auto scan operation during power-up and by direct control from a keyboard.

When scan limit stops ARE NOT set:

The dome camera will pan continuously until a manual operation from the keyboard is performed (pan, tilt, iris control, or focus).

When scan limit stops ARE set:

The dome camera will pan continuously between scan limit stops until a manual operation from the keyboard is performed (pan, tilt, iris control, or focus). To set scan limit stops; refer to **SCAN LIMIT STOPS** under **PAN/TILT SETUP**.

Zoom

At power-up, the zoom will be fully zoomed out. When an auto scan is started directly from the keyboard, the zoom will maintain the last magnification.

Tilt

At power-up, the tilt is set up by the menu. To set the tilt angle, refer to **SCAN TILT ANGLE** under **PAN/TILT SETUP**. When an auto scan is started directly from the keyboard, the tilt will maintain the last tilt angle.

FRAME SCAN

The dome camera can perform a frame scan operation during power-up and by direct control from a keyboard.

Operation of zoom and tilt is the same as in Auto Scan.

6.2 PAN/TILT FUNCTIONS

When scan limit stops ARE NOT set:

The dome camera will move in 45-degree increments (called stops) horizontally until a manual operation from the keyboard is performed (pan, tilt, iris control, or focus). See figure below.

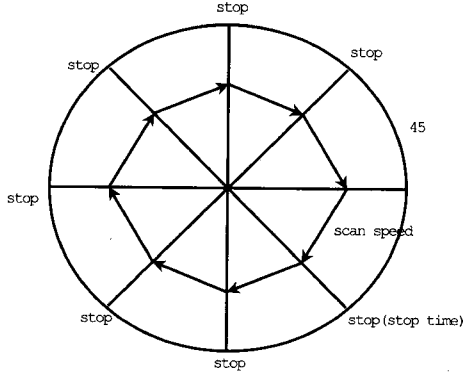

When scan limit stops ARE set:

The dome camera will move in 45-degree increments horizontally within the limit stops until a manual operation from the keyboard is performed (pan, tilt, iris control, or focus). See figure below.

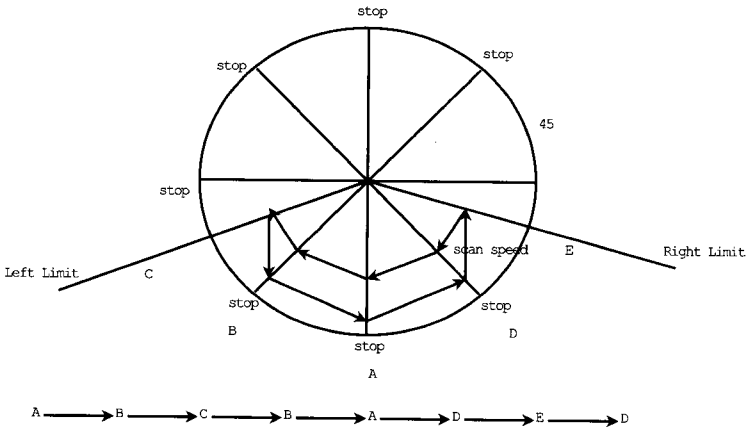

RANDOM SCAN

The dome camera can perform a random scan operation during power-up and by direct control from a keyboard.

Operation of zoom and tilt is the same as in Auto Scan.

When scan limit stops ARE NOT set:

The dome camera will move between random stops and random tilt angles until a manual operation from the keyboard is performed (pan, tilt, iris control, or focus). See figure below.

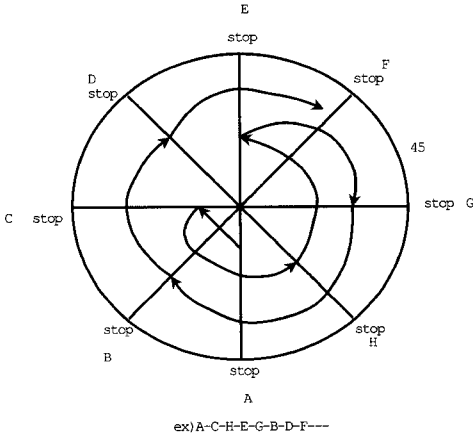

When scan limit stops ARE set:

The dome camera will move between random stops and random tilt angles within the limit stops until a manual operation from the keyboard is performed (pan, tilt, iris control, or focus). See figure below.

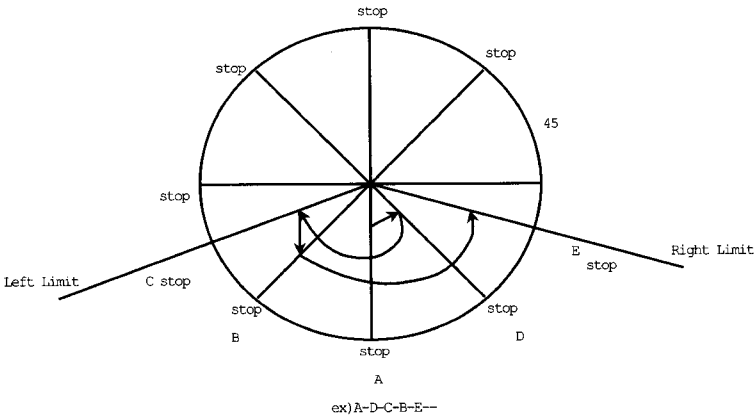

6.4 CAMERA SETUP

6.4.1 FOCUS CONTROL

Direct

- The focus can be controlled directly using near or far focusing controls.
- The focus control has 4 varying speeds.
- One Push Trigger Auto Focus is available.

Menu

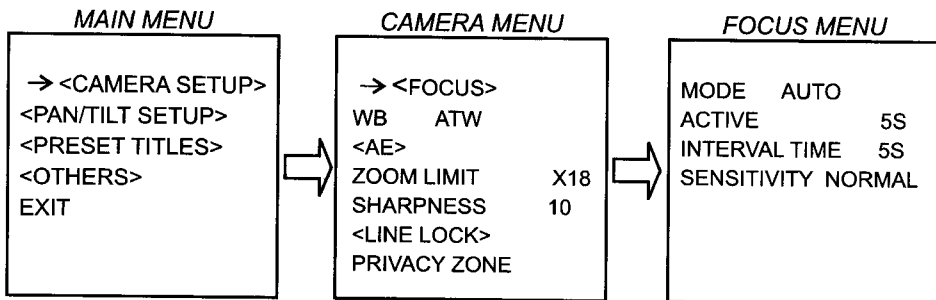

- The Focus control has four options: Manual/Auto/Interval/Zoom Trigger
- In the manual mode the IK-DP20A focus will be directly controlled with the near and far controls.
- When the camera is in Auto Mode, pressing the near and far controls will place the camera in manual mode until there is a zoom or pan/tilt function.
- In Interval mode, the camera will switch between auto focus and manual focus according to the Active Time and Interval Time respectively. Active Time (auto) → Interval Time (manual) → Active Time (auto) → Interval Time (manual) ...
- The interval and active times can be set from 1s to 255s.
- In Zoom Trigger mode, the camera remains in manual mode unless there is a zoom function and will return to manual mode after the zoom function is completed.
- The sensitivity of the Auto Focus can be set to NORMAL or LOW.

To change the Focus options:

1. Enter 95 preset to access the main menu
2. Position the cursor (→) next to CAMERA SETUP and press the OPEN button to access the Camera menu.
3. Position the cursor next to FOCUS and press the OPEN button to access the Focus menu.
4. Position the cursor next to the desired option and press the OPEN button to move the cursor to the right.
5. Move the joystick up or down to select option setting.
6. To accept the selection, press the OPEN button or to cancel the selection, press the CLOSE button.

6.4.2 WHITE BALANCE CONTROL

Direct

- The White Balance can be set by One Push Trigger operation.

Menu

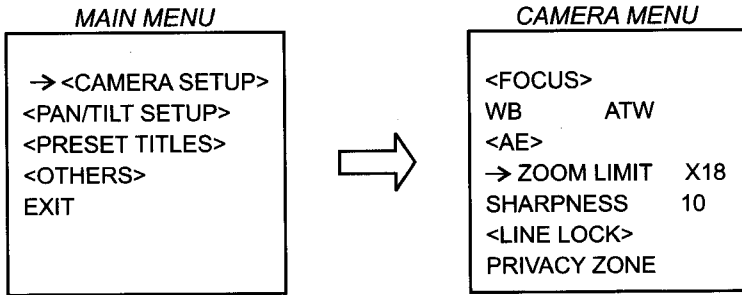

- The White Balance can be set to ATW (Auto Tracking White)/AUTO/ONE PUSH WB.
- ATW automatically adjusts the white balance for color temperatures from 2000K to 10000K.
- AUTO automatically adjusts the white balance for color temperatures from 3000K to 7500K.
- ONE PUSH WB can be set using 73 PRESET from a controller.

To change the White Balance:

1. Enter 95 preset to access the main menu.
2. Position the cursor (->) next to CAMERA SETUP and press the OPEN button to access the Camera menu.
3. Position the cursor next to WB and press the OPEN button to move the cursor to the right.
4. Move the joystick up or down to select ATW, AUTO, or ONE PUSH WB.
5. To accept the selection, press the OPEN button or to cancel the selection, press the CLOSE button.

6.4.3 AE CONTROL

Direct

- The Iris can be controlled directly using OPEN or CLOSE controls.

Menu

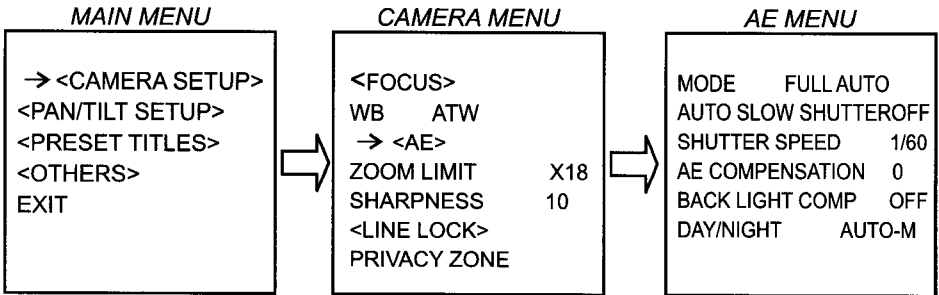

- AE (Auto Exposure) mode can be set to FULL AUTO or SHUTTER PRIORITY.
- In FULL AUTO mode, the shutter is fixed at 1/60 sec and the camera will automatically adjust the iris according to the light level.
- In FULL AUTO mode, the iris can be controlled manually but will return to FULL AUTO if there is a zoom or pan/tilt operation.
- In SHUTTER PRIORITY, the shutter can be varied from 1 sec ~ 1/10000 in 22 steps.
- Auto Slow Shutter can be set ON or OFF.
- AE Compensation can be set from 7 to +7.
- Back light compensation can be set ON or OFF. Back light compensation can be set directly using a JK-UC1 Controller (Backlight ON/OFF or 71 PRESET=ON, 72 PRESET=OFF)
- Day/Night mode can be set AUTO or MANUAL. MANUAL mode can be set directly using a JK-UC1 controller (88 PRESET = IR Cut ON, 89 PRESET=IR Cut OFF). An infrared (IR) Cut-Filter can be disengaged from the image path for increased sensitivity in low light environments. This function will automatically engage depending on the ambient light, allowing the camera to be effective in day/night environments.

To change the AE options:

1. Enter 95 preset to access the main menu.
2. Position the cursor (→) next to CAMERA SETUP and press the OPEN button to access the Camera menu.
3. Position the cursor next to AE and press the OPEN button to access the AE menu.
4. Position the cursor next to the desired option and press the OPEN button to move the cursor to the right.
5. Move the joystick up or down to select option setting.
6. To accept the selection, press the OPEN button or to cancel the selection, press the CLOSE button.

6.4.4 ZOOM CONTROL

Direct

- The zoom feature has 4 varying speeds.
- The IK-DP20A zoom feature can be controlled directly for Wide angle or Telephoto angle.

Menu

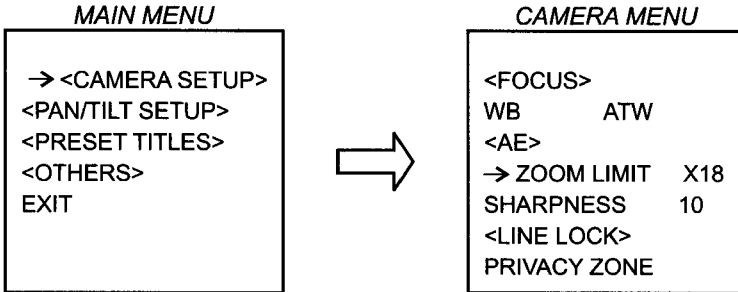

- A zoom limit can be set to x18, x36, x72, x144, and x216.
- The maximum optical zoom is x18, x36 to x216 are the values for electronic zoom.

To change the zoom limit:

1. Enter 95 preset to access the main menu.
2. Position the cursor (→) next to CAMERA SETUP and press the OPEN button to access the Camera menu.
3. Position the cursor next to ZOOM LIMIT and press the OPEN button to move the cursor to the right.
4. Move the joystick up or down to toggle between zoom limits.
5. To accept the selection, press the OPEN button or to cancel the selection, press the CLOSE button.

6.4.5 SHARPNESS CONTROL

Menu

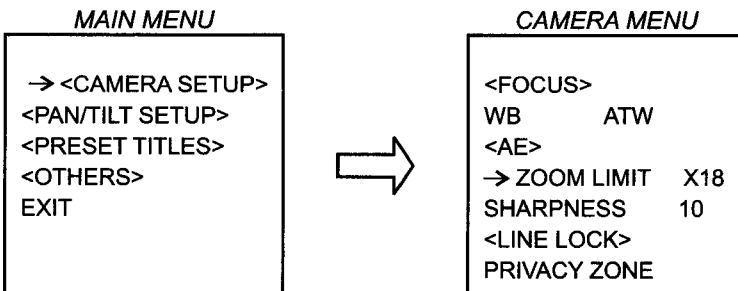

The sharpness can be controlled from 0-15, with 15 being the sharpest.

To change the SHARPNESS:

1. Enter 95 preset to access the main menu.
2. Position the cursor (→) next to CAMERA SETUP and press the OPEN button to access the Camera menu.
3. Position the cursor next to SHARPNESS and press the OPEN button to move the cursor to the right.
4. Move the joystick up or down to select the sharpness level.
5. To accept the selection, press the OPEN button or to cancel the selection, press the CLOSE button.

6.4.6 LINE LOCK CONTROL

The dome camera can be synchronized with the power supply frequency.

Menu

- Line Lock can be set to ON or OFF
- The Line Lock Phase can be set from 0 200 degrees.

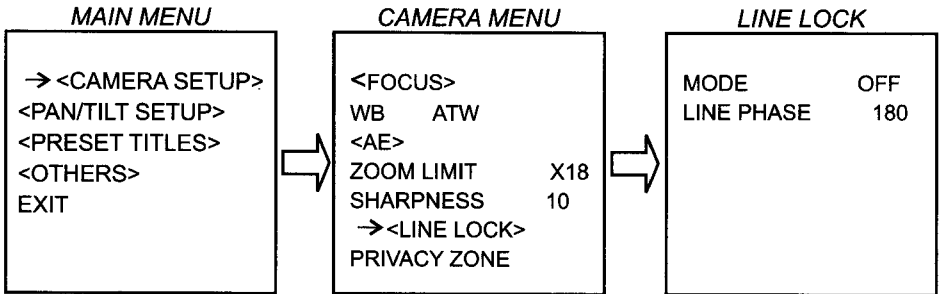

To change the LINE LOCK options:

1. Enter 95 preset to access the main menu.
2. Position the cursor (→) next to CAMERA SETUP and press the OPEN button to access the Camera menu.
3. Position the cursor next to LINE LOCK and press the OPEN button to access the Line Lock menu.
4. Position the cursor next to the desired option and press the OPEN button to move the cursor to the right.
5. Move the joystick up or down to select the option setting.
6. To accept the selection, press the OPEN button or to cancel the selection, press the CLOSE button.

6.4.7 PRIVACY ZONE MASKING

This function masks a user defined area that cannot be viewed by the operator. The mask adjusts with the pan, tilt and zoom of the camera.

Privacy Masking ON/OFF

A maximum of 8 zones can be set.

1. Enter 95 preset to access the main menu.
2. Position the cursor (→) next to CAMERA SETUP and press the OPEN button to access the menu.
3. Position the cursor next to PRIVACY ZONE and press the OPEN button to move the cursor to the right.
4. Move the joystick up or down to set P1 to P8 ON/OFF separately.
5. To accept the selection, press the OPEN button or to cancel the selection, press the CLOSE button.

Privacy zone setup

1. Enter 83 preset to access the setup screen.
Displays PRIVACY ZONE > 1 MIN
1:the number indicates zone (8 zones can be set.)
MIN: The zone will be set from a minimum size.
MAX: The zone will mask the entire image on screen.
(The actual size is slightly bigger than monitor image.
The set zone size will become smaller when zooming out.)
2. Press the OPEN button to set ZONE POSITION
The black block indicates the center of the zone.
Use a joy stick to move the black block to the center of the area to mask.
3. Press the OPEN button to set ZONE SIZE
Use a joy stick to create the privacy zone to mask.
4. Press the OPEN button to set ZONE MOVE
Use a joy stick to move the black block to mask.
5. Press the OPEN button to set ZONE COLOR
Use a joy stick to select the MASK COLOR to either Black/Gray.
6. Press the CLOSE button to move back to the previous menu.
7. Press the OPEN button again to store the settings.

In this way, a maximum of eight privacy zones can be set up.

Notes:

- 1) Masking areas are only rectangles.
- 2) While PTZ is working, the privacy zone expands 2x vertically and 4x horizontally.
- 3) Although the privacy zone works in digital zoom, the zone setting is only available in a non-digital zoom area.

- 4) It is recommended to set privacy zone bigger than actual masking area.
- 5) During turbo panning or tilting, the privacy zone may shift depending on the location of the zone.

6.5 PAN/TILT SETUP

6.5.1 AUTO FLIP

The Auto Flip feature allows the tilt to rotate 180 degrees and reposition itself for continuous viewing of a moving object directly beneath the dome.

To enable AUTO FLIP:

1. Enter 95 preset to access the main menu.
2. Position the cursor (→) next to PAN/TILT SETUP and press the OPEN button to access the Pan/Tilt menu.
3. Position the cursor next to AUTO FLIP and press the OPEN button to move the cursor to the right.
4. Move the joystick up or down to select ON or OFF.
5. To accept the selection, press the OPEN button or to cancel the selection, press the CLOSE button.

6.5.2 PROPORTIONAL P/T

Proportional P/T controls the pan and tilt speeds according to the amount of zoom. At telephoto settings, the pan and tilt speeds will be slower to keep the image from moving too fast on the monitor.

To enable PROPORTIONAL P/T:

1. Enter 95 preset to access the main menu.
2. Position the cursor (→) next to PAN/TILT SETUP and press the OPEN button to access the Pan/Tilt menu.
3. Position the cursor next to PROPORTIONAL P/T and press the OPEN button to move the cursor to the right.
4. Move the joystick up or down to select ON or OFF.
5. To accept the selection, press the OPEN button or to cancel the selection, press the CLOSE button.

6.5.3 SCAN LIMIT STOPS

When a Scan Limit Stop is reached during random, frame or auto scan, the dome camera will reverse direction. A Left Scan Limit Stop and Right Scan Limit Stop can be set. The limit stops must be greater than 10 degrees apart.

To enable SCAN LIMIT STOPS:

1. Enter 95 preset to access the main menu.
2. Position the cursor (→) next to PAN/TILT SETUP and press the OPEN button to access the Pan/Tilt menu.
3. Position the cursor next to SCAN LIMIT STOPS and press the OPEN button to move the cursor to the right.
4. Move the joystick up or down to select ON or OFF.
5. To accept the selection, press the OPEN button or to cancel the selection, press the CLOSE button.

To set SCAN LIMIT STOPS:

1. Set SCAN LIMIT STOPS to ON and exit menu.
2. Position the camera for the LEFT LIMIT STOP.
3. Enter 92 preset. SCAN LEFT LIMIT will be displayed on screen.
4. Position the camera for the RIGHT LIMIT STOP. If the right limit stop is less than 10 degrees from the left limit stop, NOT ACCEPT will be displayed on screen.
5. Enter 93 preset. SCAN RIGHT LIMIT will be displayed on screen.

6.5.4 MANUAL LIMIT STOPS

When a Manual Limit Stop is reached during a manual (joystick) pan, the camera will stop. A Left Manual Limit Stop and Right Manual Limit Stop can be set. The limit stops must be greater than 10 degrees apart.

To enable MANUAL LIMIT STOPS:

1. Enter 95 preset to access the main menu.
2. Position the cursor (→) next to PAN/TILT SETUP and press the OPEN button to access the Pan/Tilt menu.
3. Position the cursor next to MANUAL LIMIT STOPS and press the OPEN button to move the cursor to the right.
4. Move the joystick up or down to select ON or OFF.
5. To accept the selection, press the OPEN button or to cancel the selection, press the CLOSE button.

To set MANUAL LIMIT STOPS:

1. Set MANUAL LIMIT STOPS to ON and exit menu.
2. Position the camera for the LEFT LIMIT STOP.
3. Enter 90 preset. MANUAL LEFT LIMIT will be displayed on screen.
4. Position the camera for the RIGHT LIMIT STOP. If the right limit stop is less than 10 degrees from the left limit stop, NOT ACCEPT will be displayed on screen.
5. Enter 91 preset. MANUAL RIGHT LIMIT will be displayed on screen.

6.5.5 PARK TIME MINUTES

After a programmed number of minutes of inactivity, the dome camera will park to preset 1. The Park Time Minutes can be set from 1 720 minutes. Setting it to 0 will disable the feature.

To set PARK TIME MIN:

1. Enter 95 preset to access the main menu.
2. Position the cursor (→) next to PAN/TILT SETUP and press the OPEN button to access the Pan/Tilt menu.
3. Position the cursor next to PARK TIME MIN and press the OPEN button to move the cursor to the right.
4. Move the joystick up or down to set the number of minutes.
5. To accept the selection, press the OPEN button or to cancel the selection, press the CLOSE button.

6.5.6 AUTO PATROL

The Auto Patrol feature will repeat a pattern of up to 64 presets. Limit stops are ignored during Auto Patrol.

The moving speed is fixed at 300 deg/s when the STOP TIME is 10 seconds or more. However, it will become 90 deg/s if a STOP time is less than 10 seconds.

To enable AUTO PATROL:

1. Enter 95 preset to access the main menu.
2. Position the cursor (→) next to PAN/TILT SETUP and press the OPEN button to access the Pan/Tilt menu.
3. Position the cursor next to AUTO PATROL and press the OPEN button to move the cursor to the right.
4. Move the joystick up or down to scroll through the presets. Move the joystick left or right to turn the preset ON or OFF.
5. To accept the selection, press the OPEN button or to cancel the selection, press the CLOSE button.

6.5.7 SCAN SPEED

The SCAN SPEED for auto scan, random scan and frame scan can be set from 1-90 degrees/sec. However, this speed is limited by MAX SPEED.

To set SCAN SPEED:

1. Enter 95 preset to access the main menu.
2. Position the cursor (→) next to PAN/TILT SETUP and press the OPEN button to access the Pan/Tilt menu.

3. Position the cursor next to SCAN SPEED and press the OPEN button to move the cursor to the right.
4. Move the joystick up or down to set the speed.
5. To accept the selection, press the OPEN button or to cancel the selection, press the CLOSE button.

6.5.8 SCAN TILT ANGLE

The tilt angle of the dome camera for auto scan, random scan and frame scan can be set from 0 to 85 degrees or 92 degrees (0 degree is straight down).

To set SCAN TILT ANGLE:

1. Enter 95 preset to access the main menu.
2. Position the cursor (→) next to PAN/TILT SETUP and press the OPEN button to access the Pan/Tilt menu.
3. Position the cursor next to SCAN TILT ANGLE and press the OPEN button to move the cursor to the right.
4. Move the joystick up or down to set the tilt angle.
5. To accept the selection, press the OPEN button or to cancel the selection, press the CLOSE button.

6.5.9 STOP TIME

During frame scan, random scan or auto patrol, a stop time from 10 sec to 60 sec can be set. During scanning, the camera will not move for the specified time at each stop.

To set STOP TIME:

1. Enter 95 preset to access the main menu.
2. Position the cursor (→) next to PAN/TILT SETUP and press the OPEN button to access the Pan/Tilt menu.
3. Position the cursor next to STOP TIME and press the OPEN button to move the cursor to the right.
4. Move the joystick up or down to set the stop time.
5. To accept the selection, press the OPEN button or to cancel the selection, press the CLOSE button.

6.5.10 MAX SPEED

The maximum speed of Pan/Tilt functions can be set from 30 degrees/sec to 300 degrees/sec. The max speed controls global Pan/Tilt speeds. To reduce rotation noise, a lower speed is recommended.

To set MAX SPEED:

1. Enter 95 preset to access the main menu.
2. Position the cursor (→) next to PAN/TILT SETUP and press the OPEN button to access the Pan/Tilt menu.
3. Position the cursor next to MAX SPEED and press the OPEN button to move the cursor to the right.
4. Move the joystick up or down to set the maximum speed.
5. To accept the selection, press the OPEN button or to cancel the selection, press the CLOSE button.

6.6 PRESET TITLES SETUP

Titles can be set for up to 64 presets (pan/tilt position and zoom). Titles can be up to 20 characters in length and can be displayed at the top or bottom of the screen.

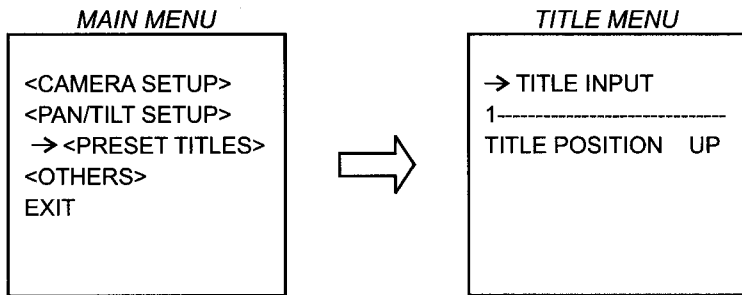

To set PRESET TITLES:

1. Enter 95 preset to access the main menu.
2. Position the cursor (→) next to PRESET TITLES and press the OPEN button to access the Title menu.
3. Press the OPEN button to move the cursor down to the title number. Move the joystick up or down to scroll through title numbers.
4. Move the joystick to the right to input the title. Move the joystick up or down to scroll through characters.
5. To accept the selection, press the OPEN button or to cancel the selection, press the CLOSE button.
6. Move the joystick down to TITLE POSITION and press open to choose UP or DOWN position of the title. UP will display the title at the top of the screen and DOWN will display the title at the bottom of the screen.
7. To accept the selection, press the OPEN button or to cancel the selection, press the CLOSE button.

6.7 OTHERS MENU

6.7.1 POWER UP

During Power-Up, the dome camera can be set to start in various modes.

PARK: The dome camera will move to Preset 1 position.

AUTO SCAN: The dome camera will perform an auto scan operation.

FRAME SCAN: The dome camera will perform a frame scan operation.

RANDOM SCAN: The dome camera will perform a random scan operation.

AUTO PATROL: The dome camera will perform an auto patrol operation.

DEFAULT: The dome camera will move to the mechanical reset point.

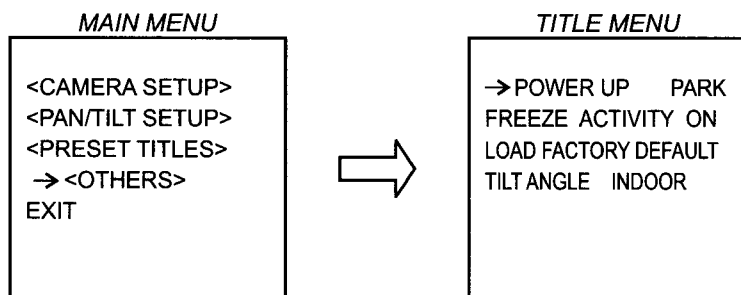

To set POWER UP MODE:

1. Enter 95 preset to access the main menu.
2. Position the cursor (→) next to OTHERS and press the OPEN button to access the menu.
3. Position the cursor next to POWER UP and press the OPEN button to move the cursor to the right.
4. Move the joystick up or down to set the power up mode.
5. To accept the selection, press the OPEN button or to cancel the selection, press the CLOSE button.

6.7.2 FREEZE ACTIVITY

During frame scan, random scan or auto patrol, a stop time from 10 sec to 60 sec can be set. During scanning, the camera will not move for the specified time at each stop.

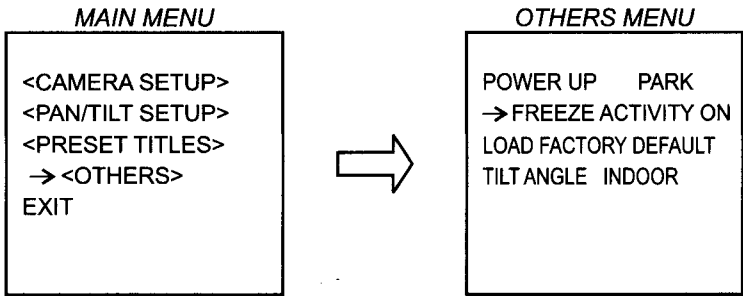

To set STOP TIME:

1. Enter 95 preset to access the main menu.
2. Position the cursor (->) next to OTHERS and press the OPEN button to access the menu.
3. Position the cursor next to FREEZE ACTIVITY and press the OPEN button to move the cursor to the right.
4. Move the joystick up or down to set freeze activity to ON or OFF.
5. To accept the selection, press the OPEN button or to cancel the selection, press the CLOSE button.

6.7.3 LOAD FACTORY DEFAULTS

The factory default settings can be loaded.

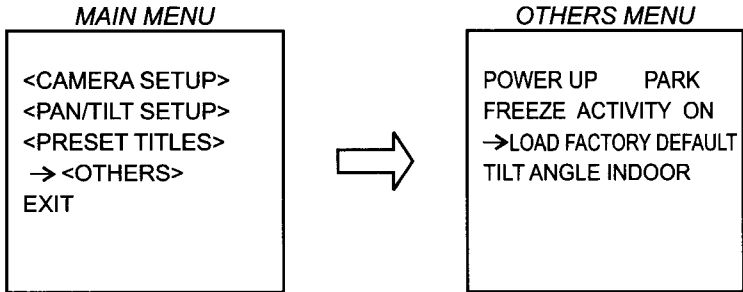

To set LOAD FACTORY DEFAULT:

1. Enter 95 preset to access the main menu.
2. Position the cursor (->) next to OTHERS and press the OPEN button to access the menu.
3. Position the cursor next to LOAD FACTORY DEFAULT and press the OPEN button twice to load factory default settings.

the cursor to the right.

4. Move the joystick up or down to set freeze activity to ON or OFF.
5. To accept the selection, press the OPEN button or to cancel the selection, press the CLOSE button.

6.7.4 TILT ANGLE

Please set up a Tilt angle according to the housing to be used and the purpose.

Indoor-85degrees MAX

Outdoor-92degrees MAX

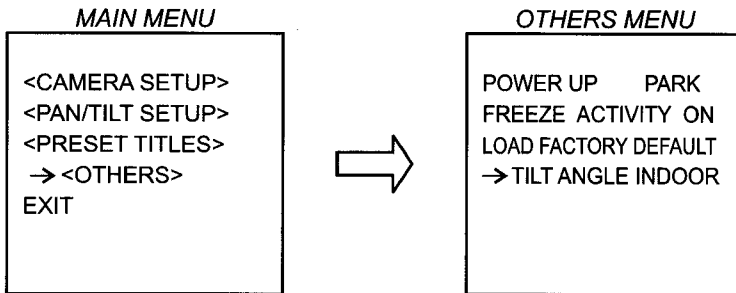

To set TILT ANGLE:

1. Enter 95 preset to access the main menu.
2. Position the cursor (->) next to OTHERS and press the OPEN button to access the menu.
3. Position the cursor next to TILT ANGLE and press the OPEN button to move the cursor to the right.
4. Move the joystick up or down to set the tilt angle mode.
5. To accept the selection, press the OPEN button or to cancel the selection, press the CLOSE button.

7. Menu Directory :

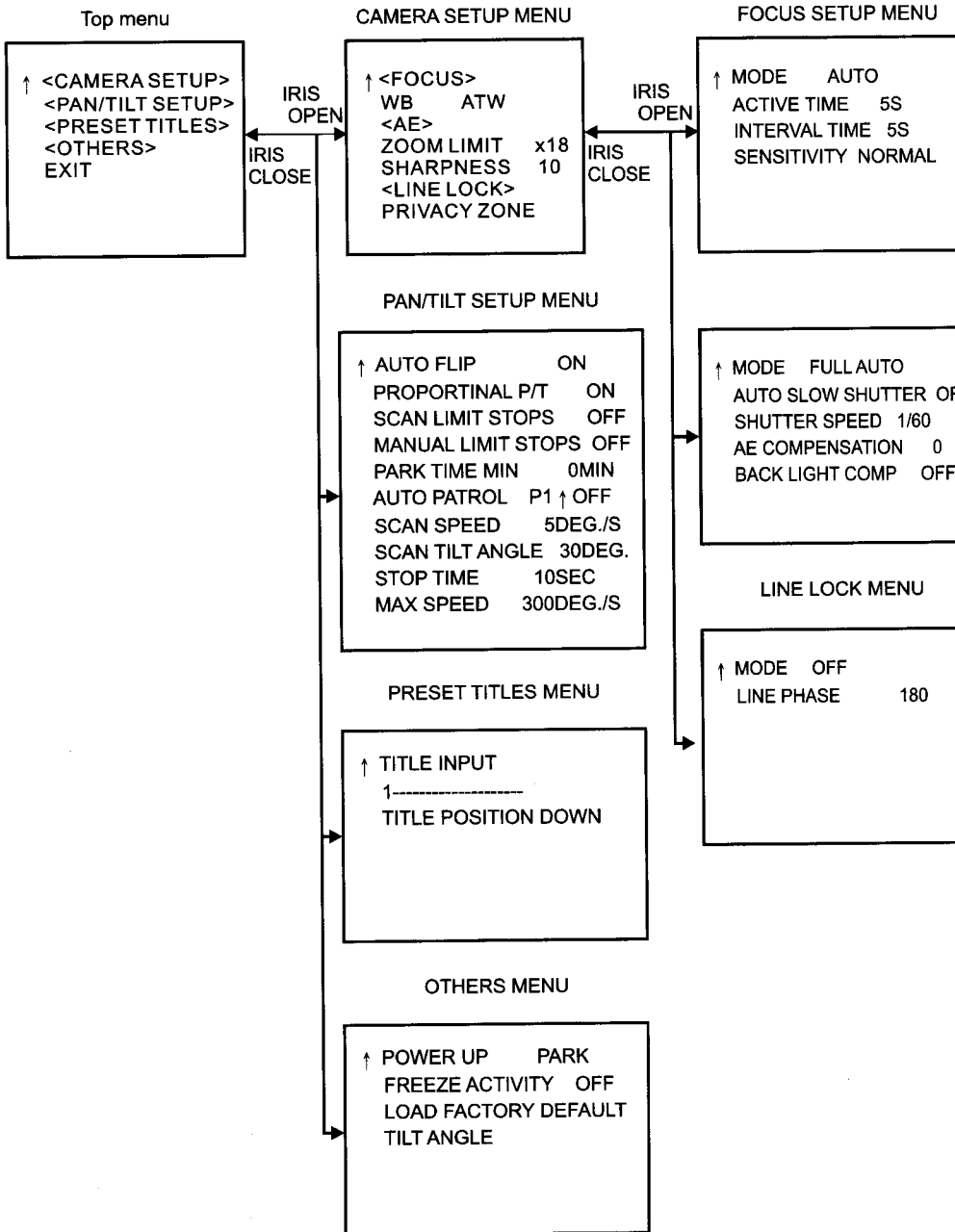

7.1 MENU LIST AND SETTINGS

Top Menu	Sub Menu1	Sub Menu2	Contents	Default
Camera Setup	Auto Exposure	Mode	Full Auto/Shutter Priority	Full Auto
		Auto Slow Shutter	On/Off	Off
		Shutter Speed	1/1~1/10000 22step	1/60
		AE Compensation	-7~+7	0
		Back Light Comp.	On/Off	Off
		Day/Night	Auto/Manual	Auto
	Zoom Limit	----	x18/36/72/144/216	x18
	Sharpness	----	0~15	10
	Line Lock	Mode	On/Off	Off
		Line Phase	40~250	180
Privacy zone	----	P1-P8	P1 ON	
Pan/Tilt Setup	Auto Flip	----	On/Off	On
	Propotional P/T	----	On/Off	On
	Scan Limit Stops	----	On/Off	Off
	Manual Limit Stops	----	On/Off	Off
	Park Time Minutes	----	0~720min	0
	Auto Patrol	----	Preset1=On/Off Preset2=On/Off	All Off
			Preset64=On/Off	
	Scan Speed	----	1~90 degree/s	5
	Scan Tilt Angle	----	0~92 degree	30
Stop Time	----	1~60 sec	10	
Max Speed	----	30~300 degree/s	300	
Preset Titles	Title input	----	It is to 20 characters to each Preset number.	All Blank
	Title Position	----	Up/Down	Down
Others	Power up	----	Default/Park/Auto Scan/ Frame Scan/Random Scan/ Auto Patrol	Park
	Freeze Activity	----	On/Off	Off
	Load Factory Default	----		
	Tilt Angle	----	Indoor/Outdoor	Outdoor

8. Preset Commands :

The dome camera can set and perform various preset commands. The following table lists the preset number and whether it can be set (SET) or performed (GO). Presets 1-32 and 35-66 are user presets. Please refer to your model's instructions for information on inputting preset commands.

Preset Number	Function
1-32 SET/GO	Preset position 1-32
33 GO	Flip
34 GO	Home (return to 0 pan position)
35-66 SET/GO	Preset position 35-66
70 GO	Begin Auto patrol
71 GO	Backlight compensation ON
72 GO	Backlight compensation OFF
73 GO	One push WB
74 GO	One push trigger AF
75 GO	Software version Display
76 GO	P/T Initialize
83 SET	Privacy Zone Setup menu mode
88 GO	IR Cut filter ON
89 GO	IR Cut filter OFF
90 SET	Set manual left limit stop
91 SET	Set manual Right limit stop
92 SET	Set Scan Left Limit Stop
93 SET	Set Scan Right Limit Stop
95 SET	Enter Menu Mode
96 GO	Stop Scan
97 GO	Begin Random Scan
98 GO	Begin Frame Scan
99 GO	Begin Auto-scan

8.1 PROGRAMMING PRESETS

Programming presets varies with the model controller being used. Several controllers are listed below. Please refer to your model's instructions for information on inputting preset commands.

JK-UC1

Input the desired preset using the numeric keypad.

Press the SHIFT key.

The LED will light up.

Press the PRESET key.

KBD200/300/300V direct

Input the desired preset number using the numeric keypad.

Hold down the PRESET button for 5 seconds to set the preset.

KBD200/300/300V CM6700 mode

Input the desired preset number using the numeric keypad.
Hold down the PRESET button until the Edit LABEL screen of CM6700 is displayed.
Press the TILT UP/DOWN button until SET is chosen.
Press the ACK button to set the preset.

MPT9500

Input the desired preset number using the numeric keypad.
Press the PRESET SET button.
Press the F2 button to set the preset.

8.2 PERFORMING PRESET OPERATIONS

JK-UC1

Input the desired preset using the numeric keypad.
Press the PRESET button to perform the preset.

KBD200/300/300V direct and CM6700 mode

Input the desired preset number using the numeric keypad.
Press the PRESET button to perform the preset.

MPT9500

Input the desired preset number using the numeric keypad.
Press the PRESET GO button to perform the preset.

9. Installation :

JK-H01A is a housing for ceiling mount of the Toshiba dome camera.

1. IK-DP20A Installation procedure

- (1) Carefully inspect to insure all parts are present and remove all parts from the box.
- (2) A template is included for ease in cutting the mounting hole. First, locate a position in the ceiling for a 9.020.08" (2292mm) hole to be drilled. Trace around the template, then cut a hole in the ceiling following the trace lines. [Note: The thickness of a ceiling to which this housing can be attached is 0.08-1.77" (2-45mm).]
- (3) Remove the dome cover. To separate the dome cover from the housing, turn the cover to the left with both hands. This dome cover is connected to the top housing with the wire. Fig-1

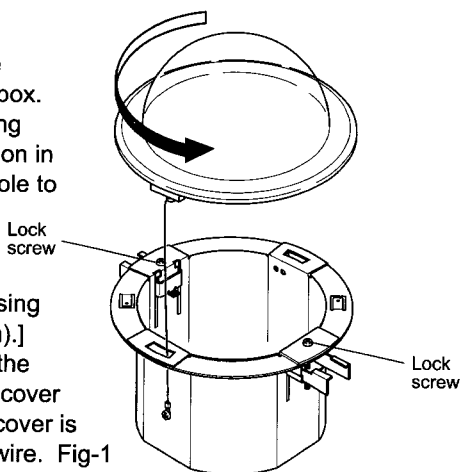

Fig-1

- (4) Loosen the lock screw according to ceiling board thickness for attaching to the ceiling.
- (5) The IK-DP20A is temporarily attached to the topside of the housing using the screws that were included with the IK-DP20A.
- (6) Do not fully tighten the screw.

(JK-H01A top housing install)

- (7) Two support arms are contained inside and attaches to the ceiling. Fig-2

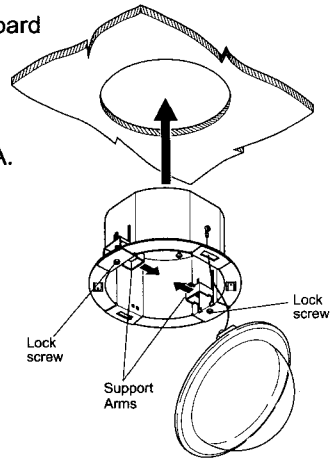

Fig-2

- (8) Put the video cable, power cable, and the communication cable inside the housing from the hole on the topside. Break a hole in the center of the housing and let the cable pass through.
- (9) Push out the support arms so that they hold onto the ceiling. Fig-3

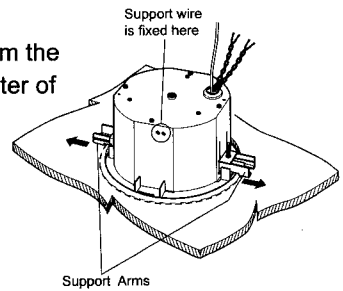

Fig-3

- (10) A lock screw is fastened from the bottom and the top housing is fixed to a ceiling. Fig-4

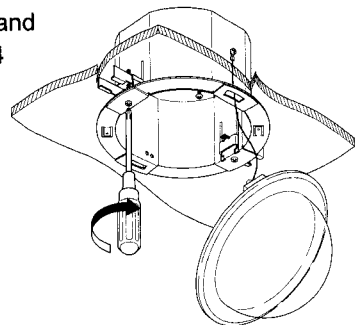

Fig-4

- (11) Use a support wire for safety.
- (12) The hole that fixes a support wire is on the side. [Note: The support wire is not attached.]

(IK-DP20A dome base install)

- (13) Attach the video cable (included with the dome accessories) to the video connector of a dome base. [Note: Do not connect a thick coaxial cable to a dome camera. There is a possibility of damaging a connector. Be sure to use the cable included in the dome accessories.]
- (14) Communication cables are directly inserted in the terminal of the dome base.
- (15) Tighten the screw to fix the dome base to the housing. Fig-5 ① ② ③

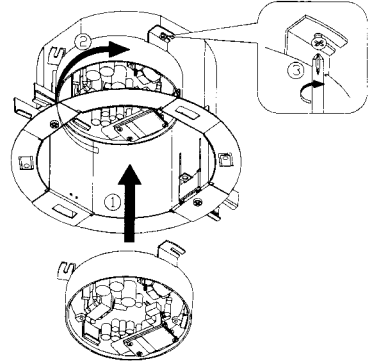

Fig-5

(IK-DP20A dome drive install)

- (16) After setting up DIP-SW in the top of the dome (See 4.switch setting), connect the support wire to the hook of the dome base. Fig-6 ①
- (17) To lock the dome drive to the dome base, line up the notch with the label and turn to the right with both hands. Fig-6 ②

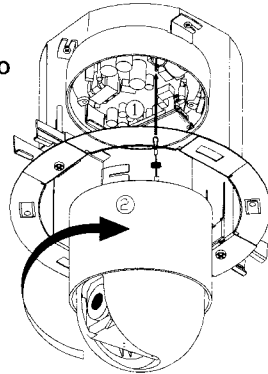

Fig-6

Ensure that the location of the notch (position of yellow paint) on the dome base and the location of the installation label on the dome drive are aligned.

(JK-H01A dome cover install)

(20) To lock the dome cover, insert the support wire and turn to the right with both hands. Fig-7, Fig-8

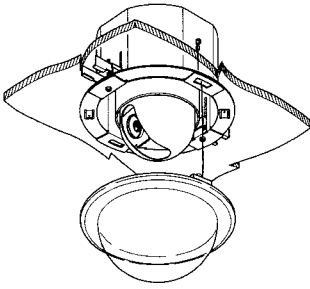

Fig-7

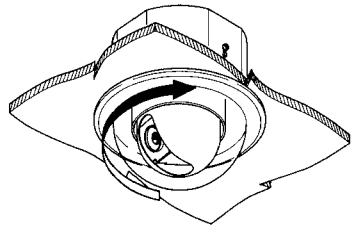

Fig-8

(21) The installation is complete.

10. Switch Setting :

There are two switches which must be set up. One is the switch which the top of a dome drive has, and another is the switch which the top of a dome base has.

(Dome drive switch)

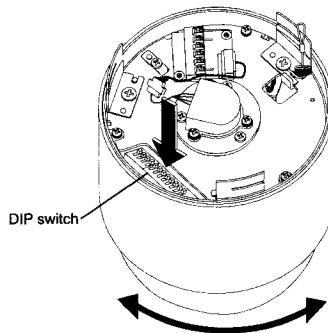

It is necessary to set a peculiar camera address, protocol, and bit rate as each camera. Please set up a camera address according to the following table.

(1) SW1 : Camera Address

Camera Address	SW1							
	bit1	bit2	bit3	bit4	bit5	bit6	bit7	bit8
1	On	Off	Off	Off	Off	Off	Off	Off
2	Off	On	Off	Off	Off	Off	Off	Off
3	On	On	Off	Off	Off	Off	Off	Off
4	Off	Off	On	Off	Off	Off	Off	Off
5	On	Off	On	Off	Off	Off	Off	Off
6	Off	On	On	Off	Off	Off	Off	Off
7	On	On	On	Off	Off	Off	Off	Off
8	Off	Off	Off	On	Off	Off	Off	Off
9	On	Off	Off	On	Off	Off	Off	Off
10	Off	On	Off	On	Off	Off	Off	Off
11	On	On	Off	On	Off	Off	Off	Off
12	Off	Off	On	On	Off	Off	Off	Off
13	On	Off	On	On	Off	Off	Off	Off
14	Off	On	On	On	Off	Off	Off	Off
15	On	On	On	On	Off	Off	Off	Off
16	Off	Off	Off	Off	On	Off	Off	Off
17	On	Off	Off	Off	On	Off	Off	Off
18	Off	On	Off	Off	On	Off	Off	Off
19	On	On	Off	Off	On	Off	Off	Off
20	Off	Off	On	Off	On	Off	Off	Off
21	On	Off	On	Off	On	Off	Off	Off
22	Off	On	On	Off	On	Off	Off	Off
23	On	On	On	Off	On	Off	Off	Off
24	Off	Off	Off	On	On	Off	Off	Off
25	On	Off	Off	On	On	Off	Off	Off
26	Off	On	Off	On	On	Off	Off	Off
27	On	On	Off	On	On	Off	Off	Off
28	Off	Off	On	On	On	Off	Off	Off
29	On	Off	On	On	On	Off	Off	Off
30	Off	On	On	On	On	Off	Off	Off
31	On	On	On	On	On	Off	Off	Off
32	Off	Off	Off	Off	Off	On	Off	Off
33	On	Off	Off	Off	Off	On	Off	Off
34	Off	On	Off	Off	Off	On	Off	Off
35	On	On	On	Off	Off	On	Off	Off
36	Off	Off	On	Off	Off	On	Off	Off
37	On	Off	On	Off	Off	On	Off	Off
38	Off	On	On	Off	Off	On	Off	Off
39	On	On	On	Off	Off	On	Off	Off
40	Off	Off	Off	On	Off	On	Off	Off
41	On	Off	Off	On	Off	On	Off	Off
42	Off	On	Off	On	Off	On	Off	Off
43	On	On	On	On	Off	On	Off	Off
44	Off	Off	On	On	Off	On	Off	Off
45	On	Off	On	On	Off	On	Off	Off
46	Off	On	On	On	Off	On	Off	Off
47	On	On	On	On	Off	On	Off	Off
48	Off	Off	Off	Off	On	On	Off	Off
49	On	Off	Off	Off	On	On	Off	Off
50	Off	On	Off	Off	On	On	Off	Off
SW Value	1	2	4	8	16	32	64	128

Camera Address	SW1							
	bit1	bit2	bit3	bit4	bit5	bit6	bit7	bit8
51	On	On	Off	Off	On	On	Off	Off
52	Off	Off	On	Off	On	On	Off	Off
53	On	Off	On	Off	On	On	Off	Off
54	Off	On	On	Off	On	On	Off	Off
55	On	On	On	Off	On	On	Off	Off
56	Off	Off	Off	On	On	On	Off	Off
57	On	Off	Off	On	On	On	Off	Off
58	Off	On	Off	On	On	On	Off	Off
59	On	On	Off	On	On	On	Off	Off
60	Off	Off	On	On	On	On	Off	Off
61	On	Off	On	On	On	On	Off	Off
62	Off	On	On	On	On	On	Off	Off
63	On	On	On	On	On	On	Off	Off
64	Off	Off	Off	Off	Off	Off	On	Off
65	On	Off	Off	Off	Off	Off	On	Off
66	Off	On	Off	Off	Off	Off	On	Off
67	On	On	Off	Off	Off	Off	On	Off
68	Off	Off	On	Off	Off	Off	On	Off
69	On	Off	On	Off	Off	Off	On	Off
228	Off	Off	On	Off	Off	On	On	On
229	On	Off	On	Off	Off	On	On	On
230	Off	On	On	Off	Off	On	On	On
231	On	On	On	Off	Off	On	On	On
232	Off	Off	Off	On	Off	On	On	On
233	On	Off	Off	On	Off	On	On	On
234	Off	On	Off	On	Off	On	On	On
235	On	On	Off	On	Off	On	On	On
236	Off	Off	On	On	Off	On	On	On
237	On	Off	On	On	Off	On	On	On
238	Off	On	On	On	Off	On	On	On
239	On	On	On	On	Off	On	On	On
240	Off	Off	On	Off	Off	On	On	On
241	On	Off	Off	Off	On	On	On	On
242	Off	On	Off	Off	On	On	On	On
243	On	On	Off	Off	On	On	On	On
244	Off	Off	On	Off	On	On	On	On
245	On	Off	On	Off	On	On	On	On
246	Off	On	On	Off	On	On	On	On
247	On	On	On	Off	On	On	On	On
248	Off	Off	Off	On	On	On	On	On
249	On	Off	Off	On	On	On	On	On
250	Off	On	Off	On	On	On	On	On
251	On	On	Off	On	On	On	On	On
252	Off	Off	On	On	On	On	On	On
253	On	Off	On	On	On	On	On	On
254	Off	On	On	On	On	On	On	On
255	On	On	On	On	On	On	On	On
SW Value	1	2	4	8	16	32	64	128

Camera Address = 1 x bit1 Status + 2 x bit2 Status + 4 x bit3 Status + 8 x bit4 Status + 16 x bit5 Status + 32 x bit6 Status + 64 x bit7 Status + 128 x bit8 Status

*bit Status: On=1,Off=0

ex) Camera Address 200 = 1 x 0(Off) + 2 x 0(Off) + 4 x 0(Off) + 8 x 1(On) + 16 x 0(Off) + 32 x 0(Off) + 64 x 1(On) + 128 x 1(On)
 = 8+64+128=200 → Off/Off/Off/On/Off/Off/On/On

(2) SW2 (bit1-2) Protocol

Protocol	bit1	bit2
TOSHIBA-P	Off	Off
TOSHIBA-D	On	Off
Reserve1	Off	On
Reserve2	On	On

(3) SW2 (bit3-4) Bit Rate

Protocol	bit3	bit4
1200bps	Off	Off
2400bps	On	Off
4800bps	Off	On
9600bps	On	On

(Dome base switch:S301)

This is RS422 termination switch located near the BNC connector.

In daisy chain operation system, the farthest dome from the controller is turned ON.

For example, when the controller is connected with three dome cameras in the direct mode, the only furthest dome camera from a controller is turned ON. The other dome camera is turned OFF. (It is OFF at the time of shipment.)

ON and OFF are as in a figure.

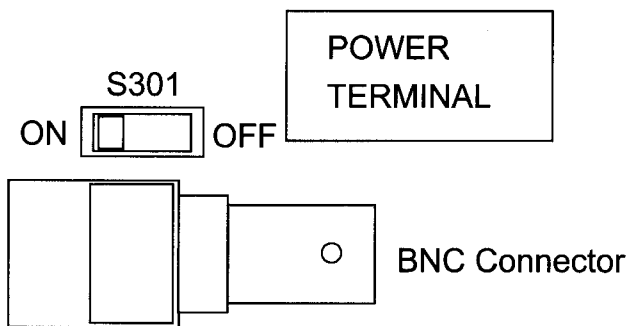

11. Specifications :

Overall

Temperature of operation	32° to 122°F (0° to 50°C)
Preservation temperature	-4° to 140°F (-20° to 60°C)
Weight	1.75 kg
Power supply	AC24V ±10% 60Hz
Power consumption	20W

Camera

Image Sensor	1/4 type IT CCD (High Sensitive CCD)
Number of Effective Pixels	768(H) x 494(V)
Lens	18xZoom f=4.1 to 73.8mm (F1.4 to F3.0)
Digital Zoom	12x(216x with optical zoom)
Angle of View (H)	approx. 48degree (wide limit) approx. 2.7degree (tele limit)
Sync. System	Internal/Line lock (AC Line lock phase adjustable)
Min. Illumination	0.7 lux typ. (1/60), 0.05 lux typ (1/4) 0.01 lux (1/4, IR Cut OFF)
S/N Ratio	more than 50dB
Resolution	480 TV lines (typ)
Electronic Shutter	1/4 to 1/10000 sec.
White Balance	Auto, ATW, One Push WB
Gain	Auto
AE Control	Full Auto, Shutter Priority, Manual
Back Light Compensation	On/Off
Auto Slow Shutter	On/Off(On : max1/4sec.)
Focusing System	Auto, Interval, Zoom Trigger, Manual
Video Output	NTSC, VBS:1.0Vp-p (Sync Negative), 75 ohm
Privacy Zone Masking	8 positions

Mechanical

Pan Range	360degrees continuous
Tilt Range	92 degrees (Outdoor)
Manual Pan Speeds	0.1° ~ 90°/s
Manual Pan Speeds(turbo)	150°/s
Manual Tilt Speeds	0.1° ~ 45°/s
Preset Speeds	Pan:300°/s Tilt:200°/s
Proportional P/T	Provided

Remote Control

I/F	RS-422 (receive only)
Protocol	Toshiba-P/D (Dip sw selectable)
Data rate	1200,2400,4800,9600bps (Dip sw selectable)

LIMITED WARRANTY

CCD SECURITY CAMERA

The Imaging Systems Division of Toshiba America Information Systems, Inc. ("ISD") makes the following limited warranties with regard to this DOME Camera ("Product"). These limited warranties extend to the Original End-User ("You/It").

One (1) Year Limited Warranty of Labor and Parts ISD warrants that this Product will perform in accordance with specifications for a period of one (1) year from the date of purchase by the Original End-User. During this one (1) year period, ISD will repair or replace the Product, if it does not perform as warranted. In order to take advantage of this Limited Warranty, You must: (a) deliver the Product to an ISD Authorized Service Provider ("ASP"); and (b) pay all transportation and insurance charges for shipment of the Product to the ASP. ISD reserves the right to substitute factory refurbished parts in place of those in need of repair.

Instruction Manual (Owner's Manual): You should read the Instruction Manual (Owner's Manual) thoroughly before operating this Product. Before seeking warranty service, you should check the troubleshooting guide in the Instruction Manual (Owner's Manual) and follow the instructions to correct the problem.

How to Obtain Warranty Service Step-by-step Procedures: To obtain warranty service, You should:

1. Contact Toshiba at (877) 855-1349 for operation or installation assistance. (877) 855-1FIX
2. Contact an ASP for warranty service within thirty (30) days after the Product fails to comply with specifications.
3. Arrange for shipment of the Product to a Toshiba Authorized Service Provider.
4. Securely pack the Product in the original carton and external shipping pack, include a letter explaining the problem with a copy of the bill of sale or proof of purchase.
5. Prepay all transportation and insurance costs.

Questions? If you have any questions, please check our web site at <http://www.toshiba.com/taisisd/security/>

Your Responsibilities: This Limited Warranty is subject to the following conditions:

1. You must provide the bill of sale or proof of purchase at the time that warranty service is required.
2. You must notify an ASP within thirty (30) days after you discover that the product does not perform in accordance with specifications during the Limited Warranty period.
3. All Warranty Service of this product must be by an ISD Authorized Service Provider.
4. You must pack the Product in its original carton using the original packing material, then insert the original carton containing the Product into another carton with additional packing material before shipping the Product to an ASP.

DISCLAIMERS:

ALL OTHER EXPRESS OR IMPLIED WARRANTIES ON THIS PRODUCT, INCLUDING THE IMPLIED WARRANTIES OF MERCHANTABILITY AND FITNESS FOR A PARTICULAR PURPOSE, ARE HEREBY DISCLAIMED. SOME STATES DO NOT ALLOW THE EXCLUSION OF IMPLIED WARRANTIES OR LIMITATIONS ON HOW LONG AN IMPLIED WARRANTY LASTS. SO THE ABOVE LIMITATIONS MAY NOT APPLY TO YOU.

IF THIS PRODUCT IS NOT IN GOOD WORKING ORDER AS WARRANTED ABOVE, YOUR SOLE AND EXCLUSIVE REMEDY SHALL BE THE REPAIR OR REPLACEMENT OF THE PRODUCT. IN NO EVENT WILL ISD OR ITS PARENT COMPANY OR ANY ASP BE LIABLE TO YOU OR ANY THIRD PARTY FOR ANY DAMAGES IN EXCESS OF THE PURCHASE PRICE OF THE PRODUCT. THIS LIMITATION APPLIES TO DAMAGES OF ANY KIND, INCLUDING ANY DIRECT OR INDIRECT DAMAGES, LOST PROFITS, LOST SAVINGS OR OTHER SPECIAL, INCIDENTAL, EXEMPLARY OR CONSEQUENTIAL DAMAGES, WHETHER FOR BREACH OF CONTRACT, TORT OR OTHERWISE, OR WHETHER ARISING OUT OF THE USE OF OR INABILITY TO USE SUCH PRODUCT, EVEN IF TAIS, ITS PARENT COMPANY, OR AN ASP HAS BEEN ADVISED OF THE POSSIBILITY OF SUCH DAMAGES OR OF ANY CLAIM BY ANY OTHER PARTY. SOME STATES DO NOT ALLOW THE EXCLUSION OR LIMITATION OF INCIDENTAL OR CONSEQUENTIAL DAMAGES FOR SOME PRODUCTS, SO THE ABOVE LIMITATIONS OR EXCLUSIONS MAY NOT APPLY TO YOU.

THIS WARRANTY GIVES YOU SPECIFIC LEGAL RIGHTS, AND YOU MAY ALSO HAVE OTHER RIGHTS WHICH MAY VARY FROM STATE TO STATE.

THIS LIMITED WARRANTY SHALL BE VOID IF THE PRODUCT OR PARTS HAVE BEEN SUBJECTED TO MISUSE, ABUSE, ACCIDENT, IMPROPER INSTALLATION, IMPROPER MAINTENANCE, OR USE IN VIOLATION OF ISD'S WRITTEN INSTRUCTIONS, OR WHERE THE PRODUCT HAS BEEN ALTERED OR MODIFIED WITHOUT ISD'S PRIOR AUTHORIZATION, OR UPON THE REMOVAL OR ALTERATION OF ISD'S FACTORY SERIAL NUMBER. LABOR SERVICE CHARGES FOR PRODUCT INSTALLATION, SET UP AND ADJUSTMENT OF CONTROLS ARE NOT COVERED BY THIS LIMITED WARRANTY.

No person, agent, distributor, dealer, authorized service provider, or company is authorized to change, modify, or extend the terms of this Limited Warranty in any manner whatsoever. The time within which an action must be commenced to enforce any obligation of ISD arising under this Limited Warranty or under any statute, or law of the United States or any state thereof, is hereby limited to one (1) year from the date You discovered should have discovered the problem. This limitation does not apply to implied warranties arising under state law. Some states do not permit limitation of the time within which You may bring an action beyond the limits provided by state law, so the above provision may not apply to You. This Limited Warranty gives You specific legal rights and You may also have other rights which vary from state to state.

TOSHIBA AMERICA INFORMATION SYSTEMS, INC.
Imaging Systems Division

TOSHIBA